

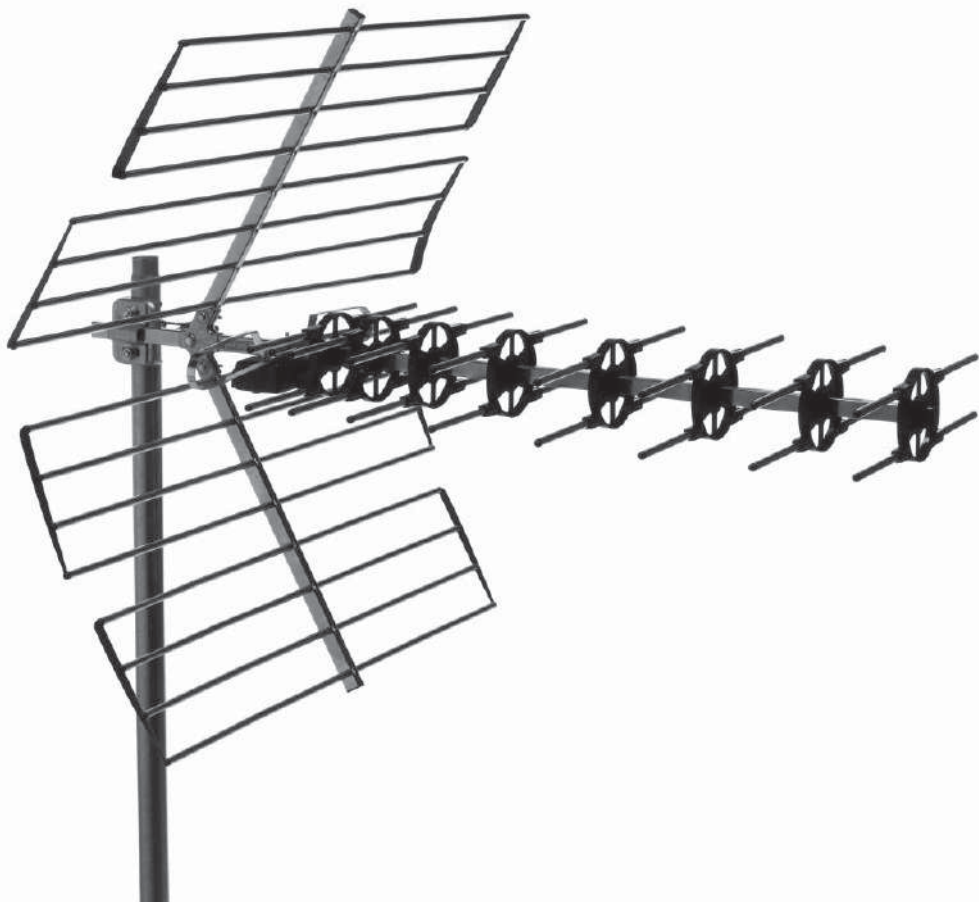

ANTENAS TV BANDA UHF
TV ANTENNAS UHF BAND
ANTENNES TV BANDE UHF



SERIE 900 SERIES

CÓMO MONTAR LA ANTENA MX-076
HOW TO MOUNT THE ANTENNA MX-076
COMMENT MONTER L'ANTENNE MX-076

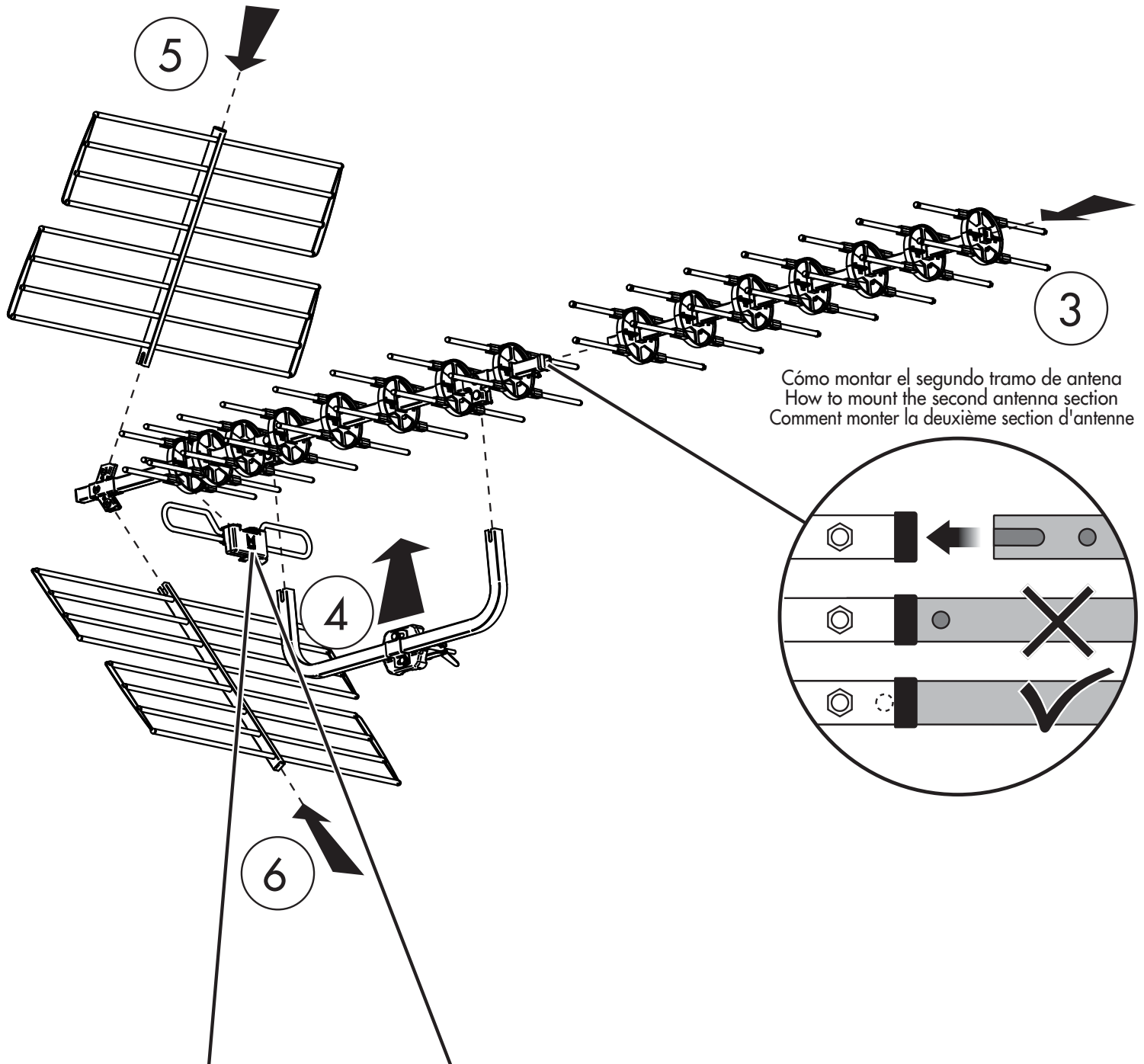

Cómo montar el segundo tramo de antena
How to mount the second antenna section
Comment monter la deuxième section d'antenne

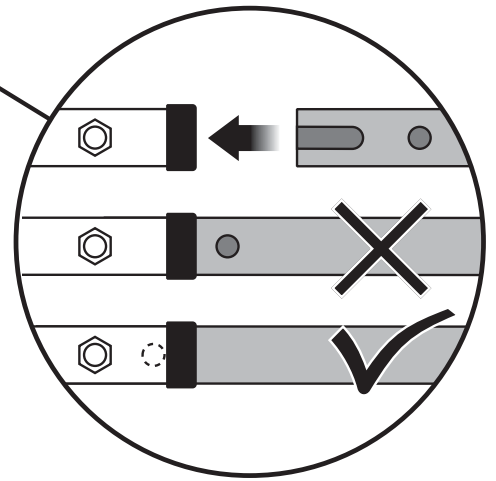

Cómo montar la caja del simetrizador
How to mount the matching transformer
Comment monter le boîtier du symétriseur

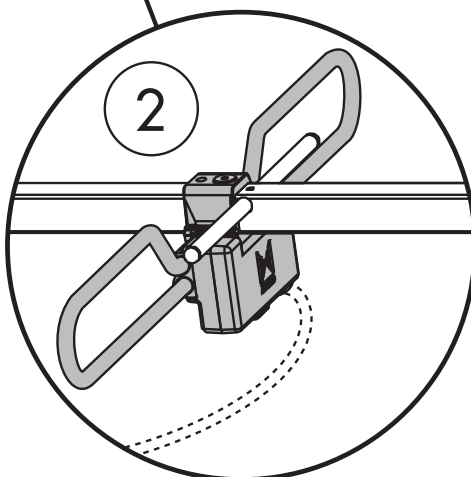
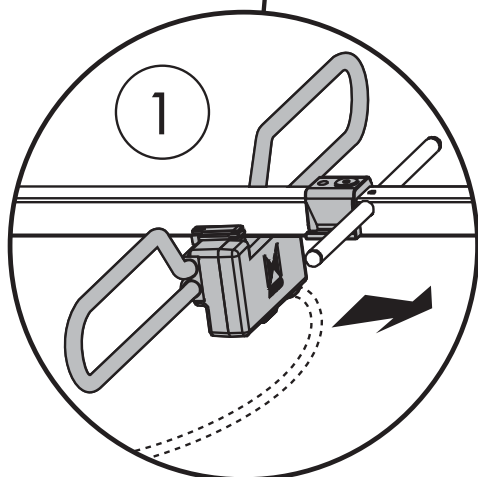

CÓMO MONTAR LA ANTENA MX-046

HOW TO MOUNT THE ANTENNA MX-046

COMMENT MONTER L'ANTENNE MX-046

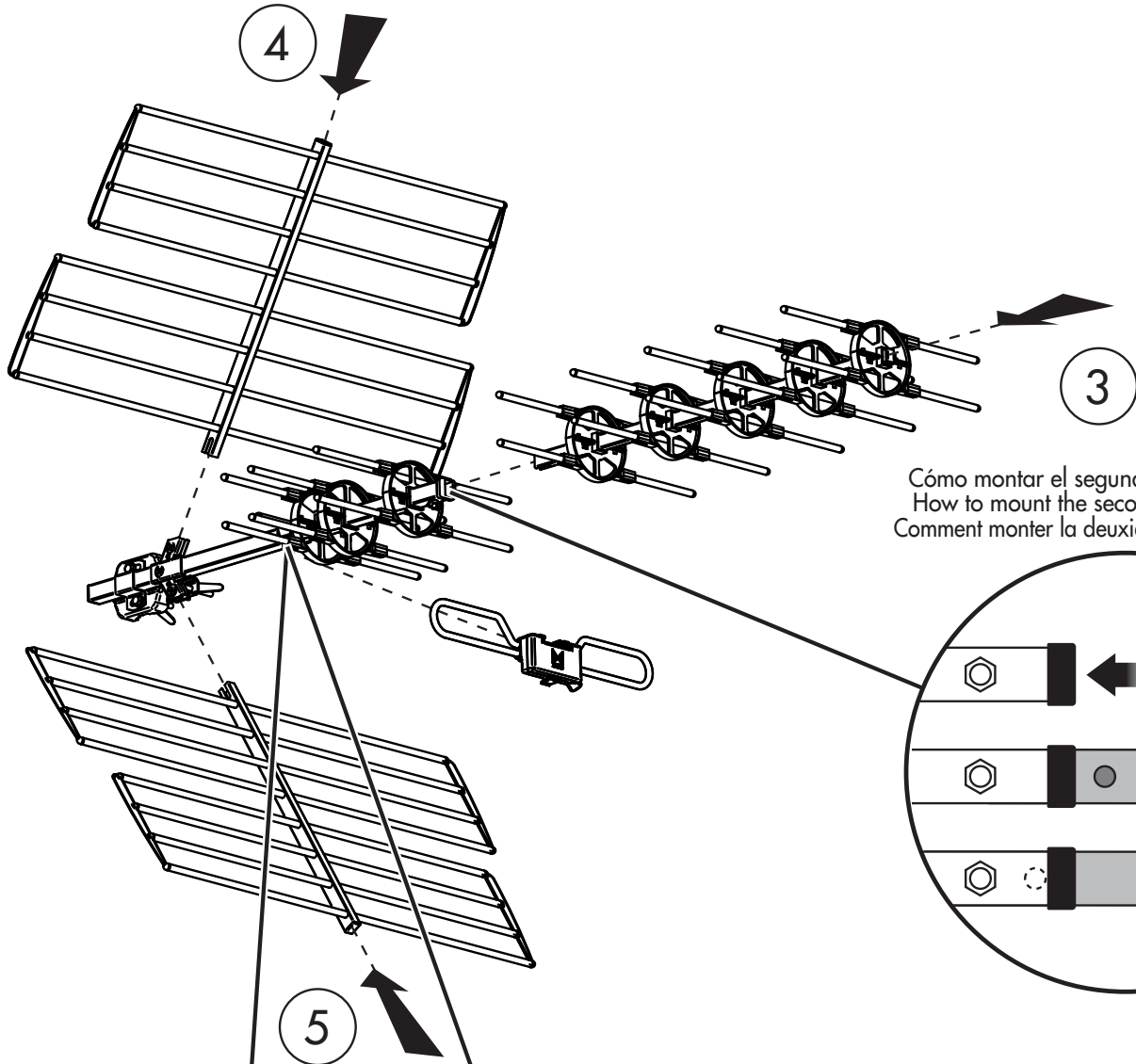

Cómo montar el segundo tramo de antena
How to mount the second antenna section
Comment monter la deuxième section d'antenne

Cómo montar la caja del simetrizador
How to mount the matching transformer
Comment monter le boîtier du symétriseur

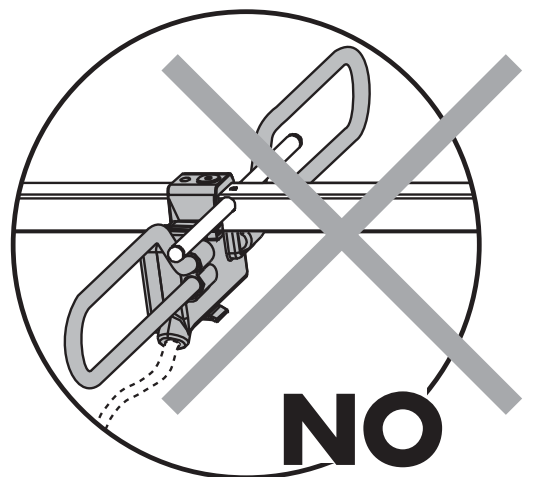
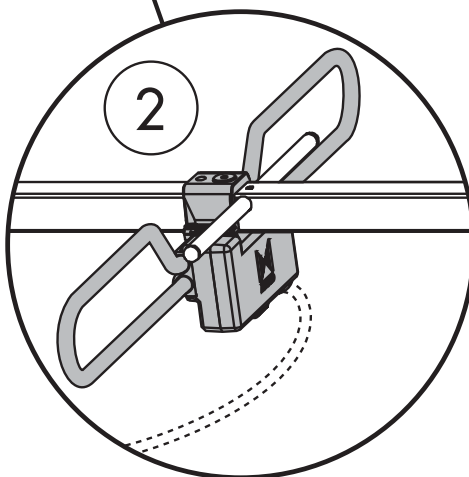
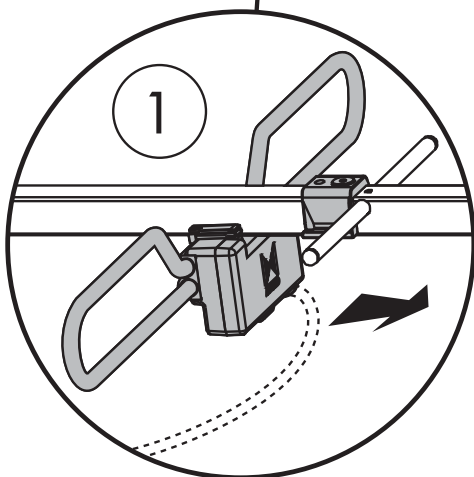

CÓMO CONECTAR EL CABLE COAXIAL EN LA CAJA DEL SIMETRIZADOR
HOW TO CONNECT THE COAXIAL CABLE TO THE MATCHING TRANSFORMER
COMMENT RELIER LE CÂBLE COAXIAL DANS LE BOÎTIER DU SYMÉTRISEUR

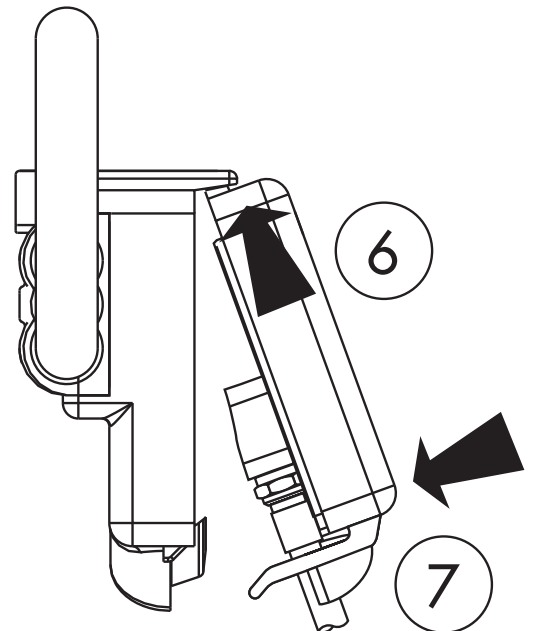
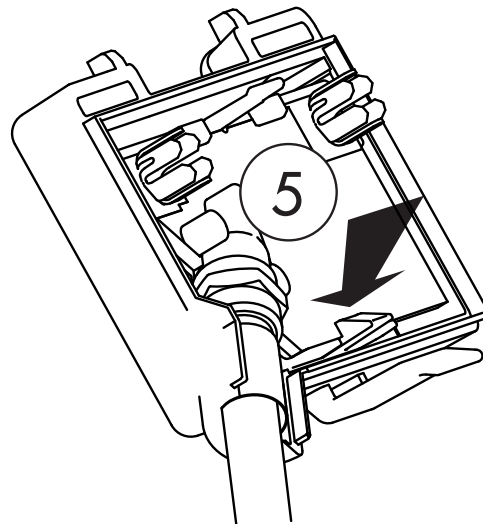
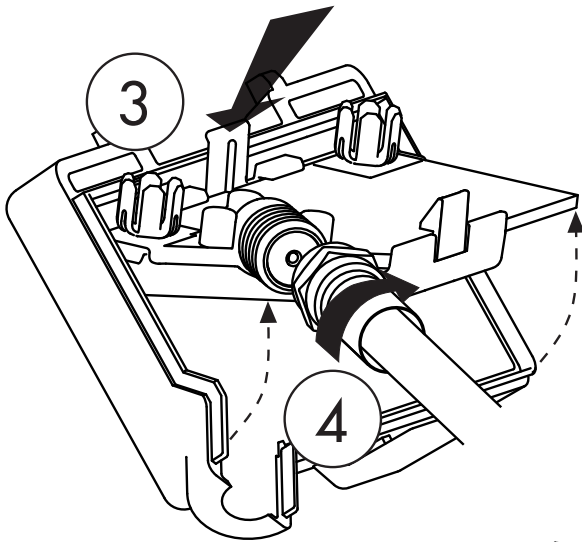
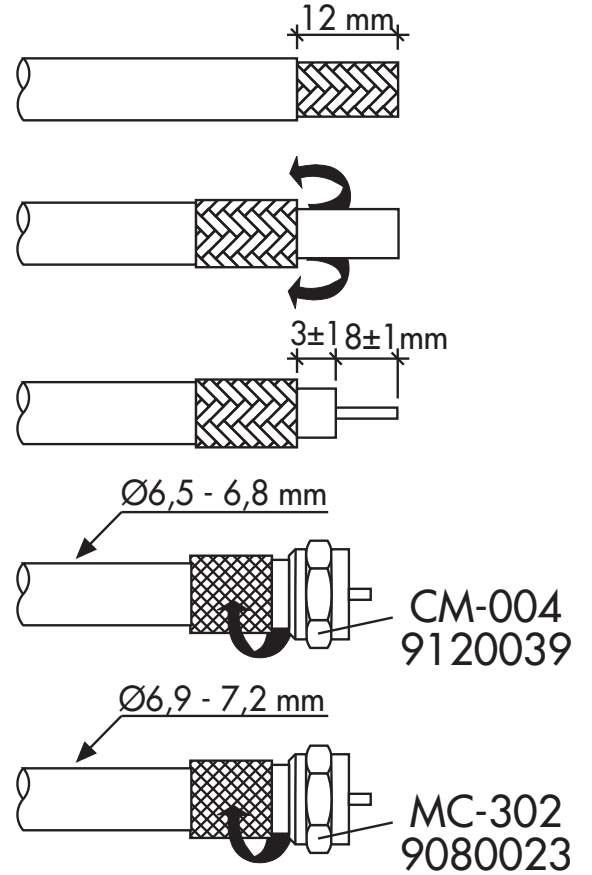
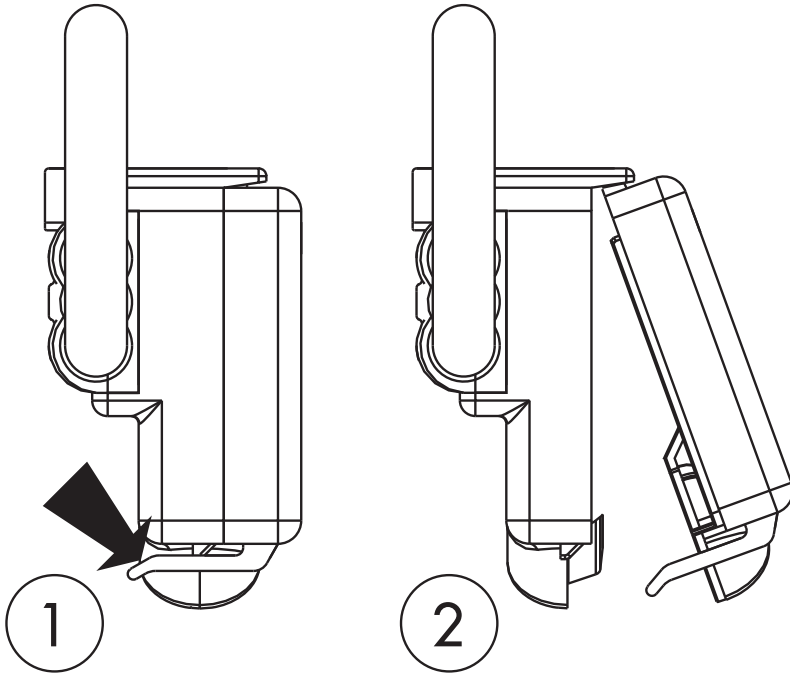

MONTAJE DE LA POLARIDAD HORIZONTAL O VERTICAL
MOUNTING IN EITHER HORIZONTAL OR VERTICAL POLARITY
MONTAGE EN HORIZONTAL OU VERTICAL

HORIZONTAL

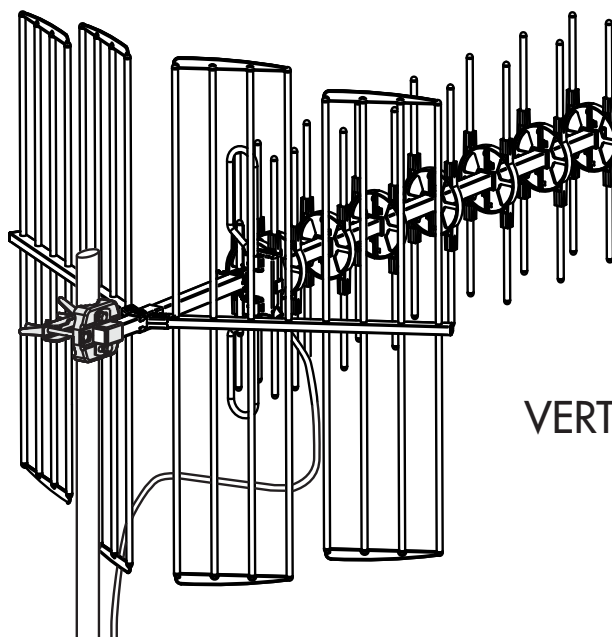
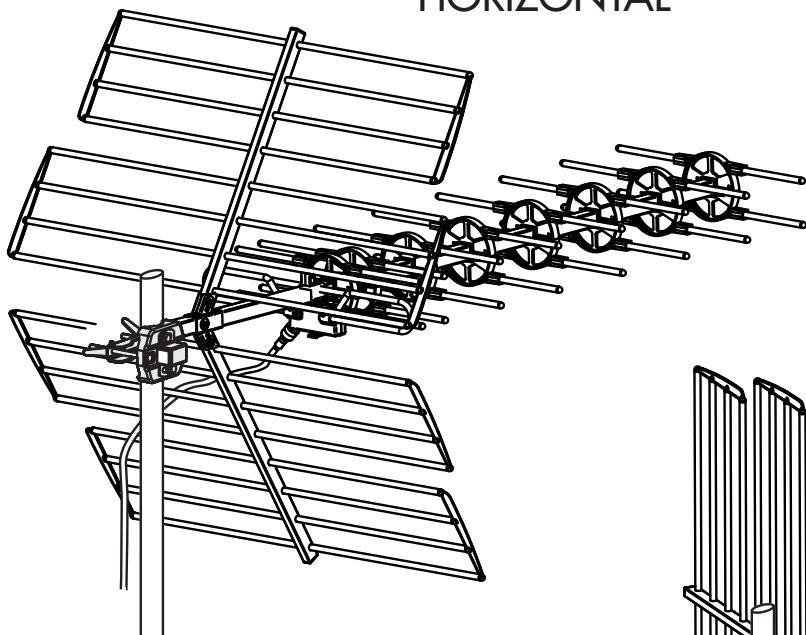

VERTICAL

AJUSTE DEL ÁNGULO DE ELEVACIÓN
ELEVATION ANGLE ADJUSTMENT
REGLAGE DE L'ANGLE D'ELEVATION

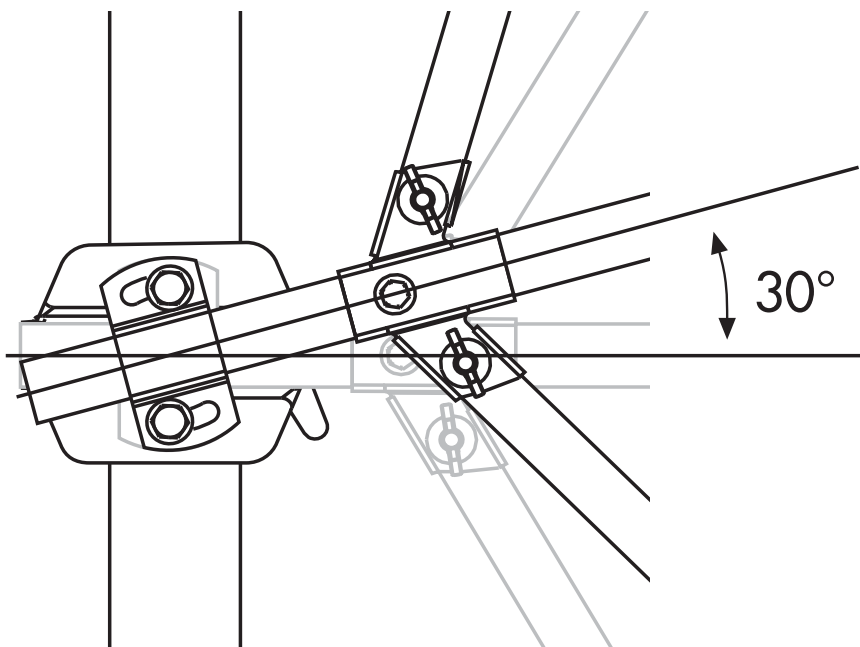

CURVA DE GANANCIA Y DIAGRAMAS DE RADIACIÓN

GAIN AND RADIATION GRAPHICS

COURBE DU GAIN ET DIAGRAMME DE RAYONNEMENT

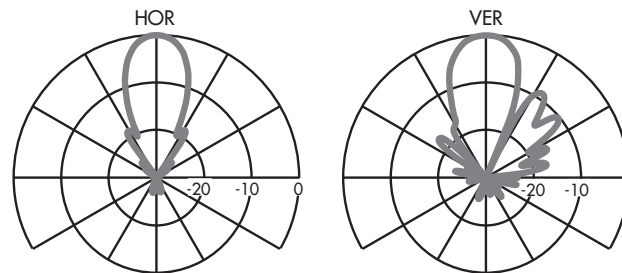
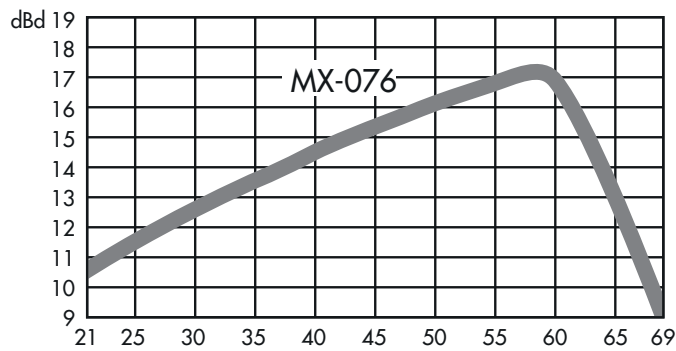
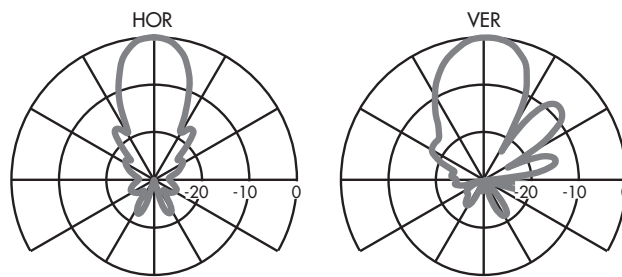
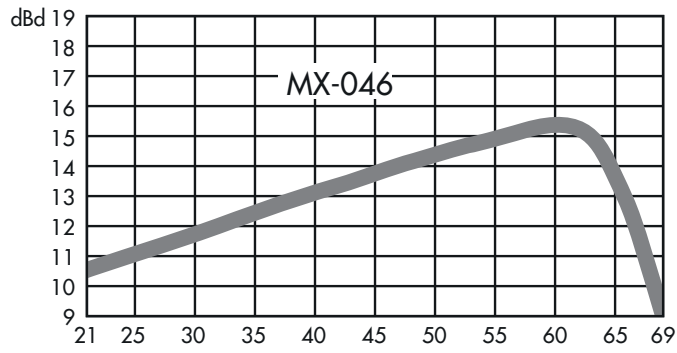

CÓDIGO-CODE-CODE		900085	900088
MODELO-MODEL-MODELE		MX-046	MX-076
Rango de frecuencias Frequency range Gamme de fréquences	MHz	470 - 790	
Canales Channels Canaux		21-60	
Ganancia Gain Gain	dBd	15,5	17,5
Relación delante/detrás Front/back ratio Rapport avant/arriere	dB	27	35
Impedancia Impedance Impédance	Ω	75	
Pérdidas de retorno Return loss Pertes de retour	dB	≥ 10	
Polarización Polarity Polarisation		HOR /VER	
Ángulo de apertura Beam width Angle d'ouverture	$^{\circ}$ H	32	22
	$^{\circ}$ V	33	29
Longitud Lenght Longueur	mm	1152	1792
Resistencia al viento Wind loading Résistance au vent	N	111	158
	H	126	167
Índice de protección Protection index Indice de protection		IP 53	

Todas las antenas incorporan simetrizador.
All antennas supplied with matching transformer.
Toutes les antennes ont un symétriseur.



DECLARATION OF CONFORMITY

according to EN ISO/IEC 17050-1:2004

Company Name: ALCAD, S.L.
Company Address: Pol. Ind. Arreche-Ugalde, 1
Apdo. 455, **20305 IRÚN** (Guipúzcoa), **SPAIN**

declares that the product

Model Number(s): MX-046, MX-076
Product Description: TV ANTENNAS UHF BAND
Product Option(s): INCLUDING ALL OPTIONS
is in conformity with:

Safety: EN 60728-11:2005

The product herewith complies with the requirements of the Low Voltage Directive 2006/95/EC and the EMC Directive 2004/108/EC.

Supplementary Information: To comply with these directives, do not use the products without covers and operate the system as specified.



Irún (SPAIN), 28 Jun 2013

Xabier Isasa
General Manager



ALCAD, S.L.
Tel. 943 63 96 60
Fax 943 63 92 66
Int. Tel. +34 - 943 63 96 60
info@alcad.net
Apdo. 455 - Pol. Ind. Arreche-Ugalde, 1
20305 IRUN - Spain
www.alcad.net

FRANCE - Hendaye
Tel. 00 34 - 943 63 96 60

GERMANY - Munich
Tel. 089 55 26 480

CZECH REPUBLIC - Ostrova čice
Tel. 546 427 059

UNITED ARAB EMIRATES - Dubai
Tel. 971 4 887 19 50

TURKEY - Istanbul
Tel. 212 295 97 00



ISO 9001

