

# 900

ANTENAS TV BANDA UHF  
TV ANTENNAS UHF BAND  
ANTENNES TV BANDE UHF

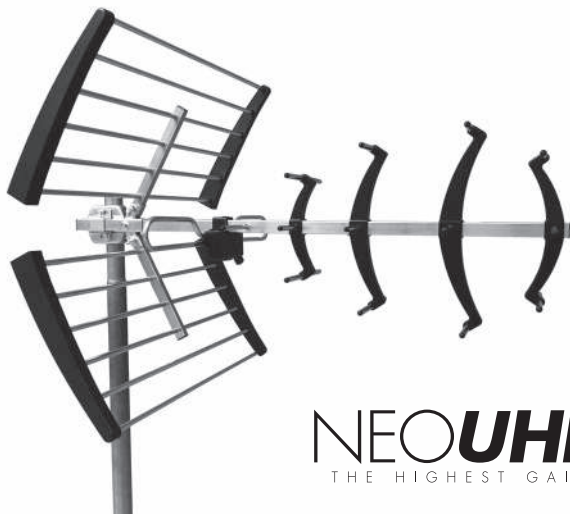

**NEOUHD**  
THE HIGHEST GAIN

CÓDIGO-CODE-CODE		9000113
MODELO-MODEL-MODELE		NEO-148
Rango de frecuencias Frequency range Gamme de fréquences	MHz	470-790
Canales Channels Canaux		21-60
Ganancia Gain Gain	dBi	25,3
Nivel máximo Output level Niveau de sortie	dB $\mu$ V	100
Figura de ruido Noise figure Facteur de bruit	dB	3,0 $\pm$ 0,5
Relación delante/detrás Front/back ratio Rapport avant/arriere	dB	30
Impedancia Impedance Impédance	$\Omega$	75
Pérdidas de retorno Return loss Pertes de retour	dB	$\geq$ 10
Polarización Polarity Polarisation		HOR /VER
Ángulo de apertura Beam width Angle d'ouverture	$^{\circ}$ H	46
	$^{\circ}$ V	56
Longitud Lenght Longueur	mm	800
Resistencia al viento Wind loading Résistance au vent	N   H	105
	N   V	90
Alimentación Power supply Alimentation	V $\cdots$	24
	mA	10
Índice de protección Protection index Indice de protection		IP 53

Todas las antenas incorporan simetrizador activo.  
All antennas supplied with active matching transformer.  
Toutes les antennes ont un symétriseur actif.

# CÓMO MONTAR LA ANTENA

## HOW TO MOUNT THE ANTENNA

### COMMENT MONTER L'ANTENNE

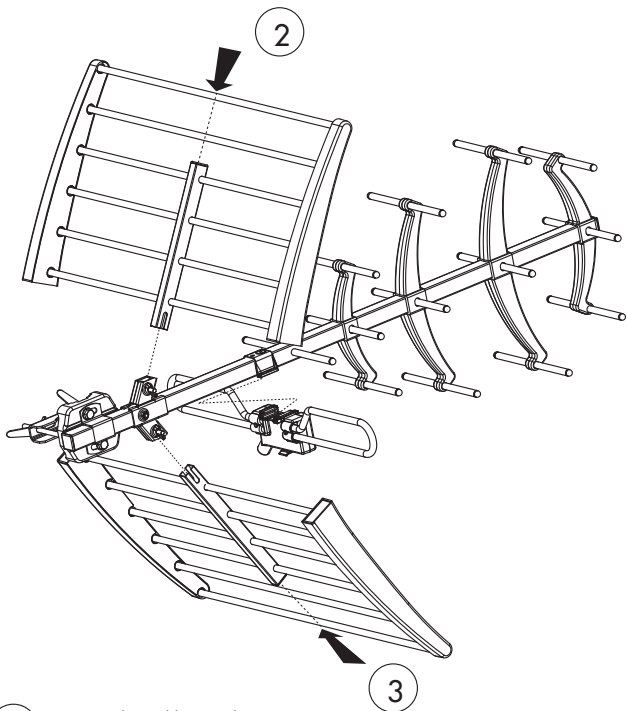

- 1** Cómo montar la caja del simetrizador activo  
How to mount the active matching transformer  
Comment monter le boîtier du symétriseur actif

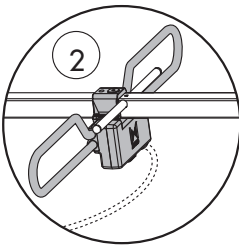
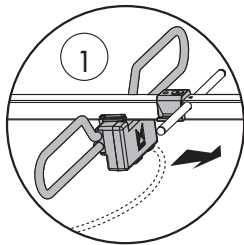

CÓMO CONECTAR EL CABLE COAXIAL EN LA CAJA DEL SIMETRIZADOR  
HOW TO CONNECT THE COAXIAL CABLE TO THE MATCHING TRANSFORMER  
COMMENT RELIER LE CÂBLE COAXIAL DANS LE BOÎTIER DU SYMÉTRISEUR

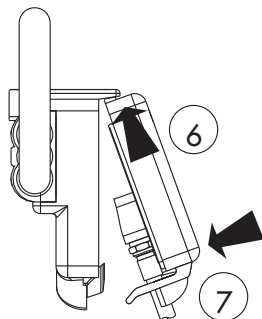
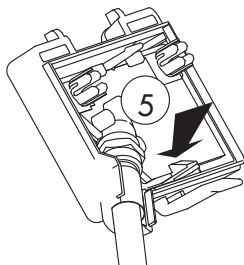
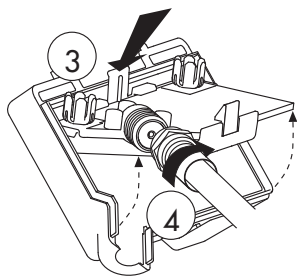
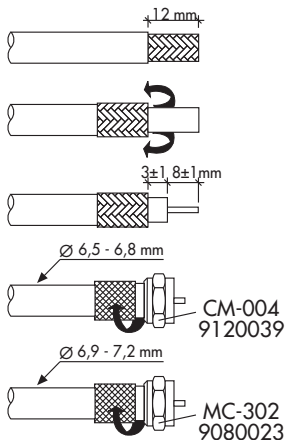
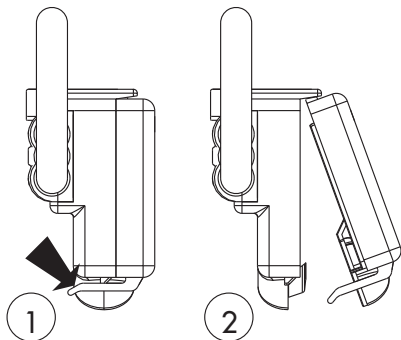

MONTAJE DE LA POLARIDAD HORIZONTAL O VERTICAL  
MOUNTING IN EITHER HORIZONTAL OR VERTICAL POLARITY  
MONTAGE EN HORIZONTAL OU VERTICAL

---

HORIZONTAL

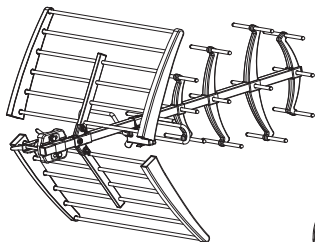

VERTICAL

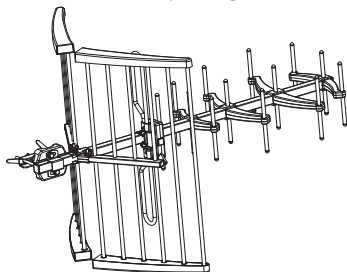

AJUSTE DEL ÁNGULO DE ELEVACIÓN  
ELEVATION ANGLE ADJUSTMENT  
RÉGLAGE DE L'ANGLE D'ÉLEVATION

---

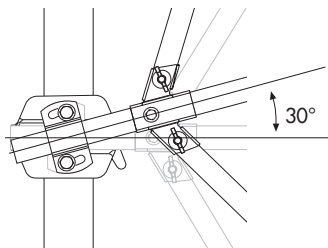

# CURVA DE GANANCIA Y DIAGRAMAS DE RADIACIÓN

## GAIN AND RADIATION GRAPHICS

### COURBE DU GAIN ET DIAGRAMME DE RAYONNEMENT

---

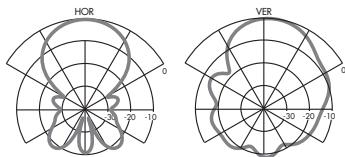
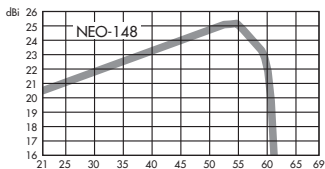

# ESQUEMAS TÍPICOS

## CONNECTION DIAGRAMS

### SCHEMAS DE CONNEXION

---

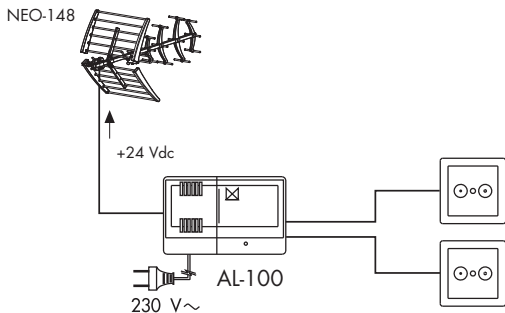

ESQUEMAS TÍPICOS  
 CONNECTION DIAGRAMS  
 SCHEMAS DE CONNEXION

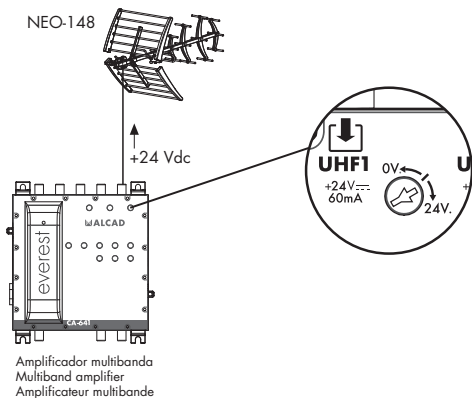
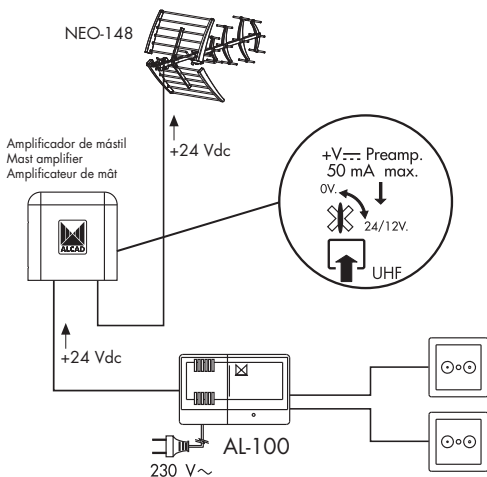

Por la presente, ALCAD Electronics, S.L. declara que los tipos de equipo radioeléctrico NEO-148 son conformes con la Directiva 2014/53/UE. El texto completo de la declaración UE de conformidad está disponible en la dirección internet [www.alcad.net](http://www.alcad.net), buscando los productos con la casilla Buscador.

Hereby, ALCAD Electronics, S.L. declares that the radio equipment type NEO-148 are in compliance with Directive 2014/53/EU. The full text of the EU declaration of conformity is available at the internet address [www.alcad.net](http://www.alcad.net), searching the products with the Search box.

Le soussigné, ALCAD Electronics, S.L., déclare que les équipements radioélectriques du type NEO-148 sont conformes à la directive 2014/53/UE. Le texte complet de la déclaration UE de conformité est disponible à l'adresse internet [www.alcad.net](http://www.alcad.net), en recherchant les produits avec le champ de Recherche.



La versión actual de esta Declaración UE de conformidad está disponible en [www.alcad.net](http://www.alcad.net)  
The updated version of this UE Declaration of conformity is available on [www.alcad.net](http://www.alcad.net)  
La version actuelle de cette Déclaration UE de conformité est disponible sur [www.alcad.net](http://www.alcad.net)

Especificaciones sujetas a modificación sin previo aviso  
Specifications subject to modifications without prior notice  
Les spécifications sont soumises à de possible modifications sans avis préalable



**ALCAD Electronics, S.L.**  
Tel. 943 63 96 60  
Fax 943 63 92 66  
Int. Tel. +34 - 943 63 96 60  
[info@alcad.net](mailto:info@alcad.net)  
Apdo. 455 - Pol. Ind. Arreche-Ugalde, 1  
20305 IRUN - Spain

[www.alcadelectronics.com](http://www.alcadelectronics.com)

**FRANCE** - Hendaye  
Tel. + 34 - 943 63 96 60  
**CZECH REPUBLIC** - Ostrovačice  
Tel. +420 546 427 059  
**UNITED ARAB EMIRATES** - Dubai  
Tel. +971 4 214 61 40  
**TURKEY** - Istanbul  
Tel. +90 212 295 97 00



**ISO 9001**

